



Power & Signal Transfer Units SPB03

The SPB03 units use fibreglass reinforced polyester enclosures. They have been designed to provide an ideal method of transferring power or power signals, including multiplexing, when using precious metal plated rings for low noise applications. Our standard range of slip rings and brushgear (up to a rating of 35 amps maximum continuous load per way, 690V a/c phase rings and 400V a/c earth/ground rings) can be accommodated, and the all-insulated fibreglass reinforced polyester enclosure is light-weight and fully dust and weatherproofed to I.P. 65, when the mounting flange is correctly sealed. Mounting flanges can be designed to suit customers' requirements. Special units can be offered for applications with higher power. The new unit is vandal proof and service friendly.

Enquiries for these units should include the following information:-

- > Number of ways required
- > Load per ring (amps and voltage) or details of signals to be carried by slip rings
- > Speed of rotation
- > Mounting flange required and cable gland entry
- > Ambient working temperature
- > Cable gland entries required in base
- > Voltage should anti-condensation heater be required

Single Entry

NOTE: The SPB03 is compliant to WIMES directive 2.01 section 6.12.2 for rotating half bridge scrapers.

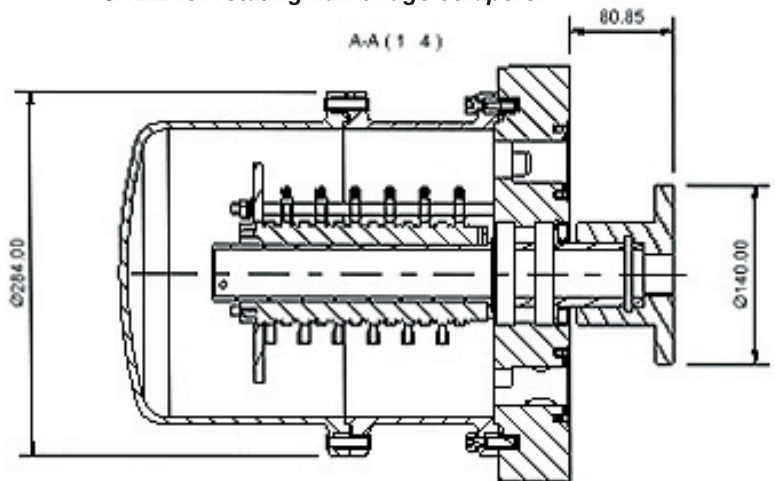
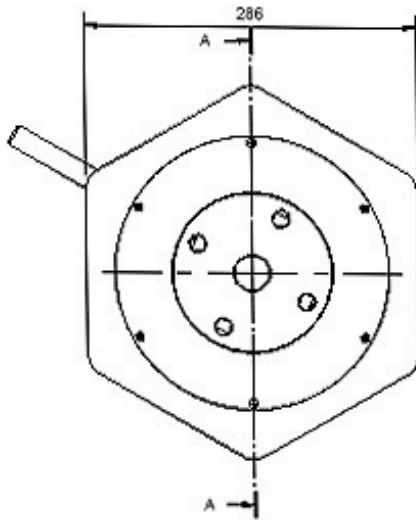

Number of Spacers/ Ways/ Length		
No. of Spacers	No of Ways / Slip Rings	DIM A
0	8 Ways (1 x 8 Way J)	315.5
1	12 Ways (1 x 12 Way J)	433
2	20 Ways (2 x 10 Way J)	550.5
3	24 Ways (2 x 12 Way J)	668
4	30 Ways (3 x 10 Way J)	785.5
5	36 Ways (3 x 12 Way J)	903

